

# TEMPERATURE-COMPENSATED CRYSTAL OSCILLATOR

## TX097, VTX97



### Applications

- GPS / LTE / Femtocell

### Features

- Ultra-thin / Dimensions (2.0×1.6×0.8)
- Seam sealed
- Low phase noise / Low power consumption
- High stability  $\pm 0.5\text{ppm} / -40\sim+85^{\circ}\text{C}$

### Specifications



Model		TX097	VTX97
Frequency range		13~52MHz	
Nominal frequency (MHz)		19.2, 26, 38.4, 52	
Frequency stability	Tolerance at 25°C	$\pm 2.0 \times 10^{-6}$ (Sixty minutes after reflow)	
	Temperature (Ref.to+25°C)	$\pm 0.5 \times 10^{-6} / -40\sim+85^{\circ}\text{C}$	
	Supply voltage change	$\pm 0.2 \times 10^{-6} / V_{\text{dd}} \pm 5\%$	
	Load change	$\pm 0.2 \times 10^{-6} / Z_L \pm 10\%$	
Aging (at 25°C)		$\pm 1.0 \times 10^{-6} / \text{year at } +25^{\circ}\text{C}$	
Storage temperature range		-40~+85°C	
Power supply voltage (Vcc)		+1.8V~+3.3V DC $\pm 5\%$	
Current consumption		1.5mA max. (~26MHz), 2.0mA max. (~32MHz), 2.5mA max. (~52MHz)	
Output	Load (ZL)	10k $\Omega$ //10pF	
	Voltage	0.8V p-p min.	
	Waveform	Clipped Sine Wave (DC-coupled output)	
External controlfunction	Frequency tuning range	-	$\pm 8.0 \times 10^{-6}$ min. (Positive)
	External control voltage	-	+1.5V $\pm 1.0\text{V}$ DC / +0.9V $\pm 0.9\text{V}$ DC
	Input impedance (Zvin)	-	500k $\Omega$ min. (770k $\Omega$ typ.)
Phase noise		-135dBc typ. at 1kHz offset	

Package quantity: 3,000pcs max./Reel.

### Outline and Dimensions [unit:mm]

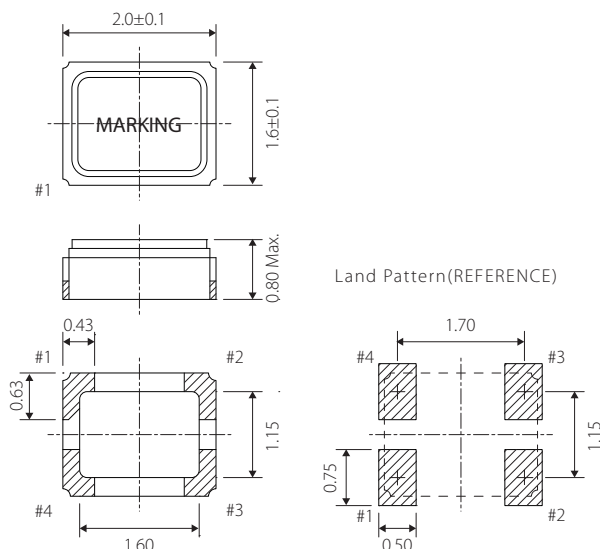

Terminal	Connection	
	TX097	VTX97
#1	GND	VC
#2	GND	GND
#3	OUTPUT	OUTPUT
#4	Vcc	Vcc